

DETAY A
DETAIL A

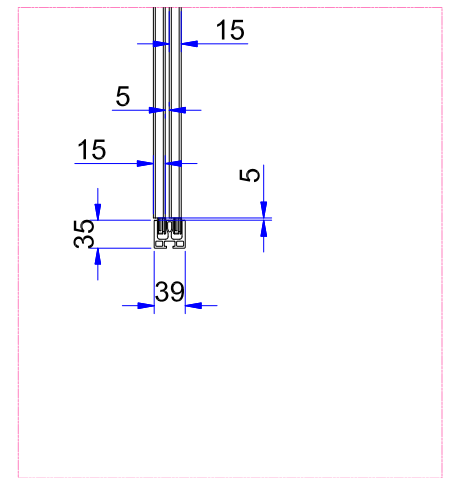

DETAY B
DETAIL B

NA / CO : Net Giriş Açıklığı / Clear Opening
MG / MW : Mekanizma Genişliği / Mechanism Width
E / S : Eşik Uzunluğu / Sill Length
PG / PW : Panel Genişliği / Panel width

NET GİRİŞ AÇIKLIĞINA GÖRE DEĞİŞEN DEĞERLER

NA/CO	700	750	800	850	900	950	1000	1050	1100	1150	1200
E/S(mm)	1270	1353,5	1437	1520,5	1604	1687,5	1771	1854,5	1938	2021,5	2105
MG/MW(mm)	1270	1353,5	1437	1520,5	1604	1687,5	1771	1854,5	1938	2021,5	2105
PG/PW(mm)	255,7	272,7	289,7	306,7	323,7	340,7	357,7	374,7	391,7	408,7	425,7

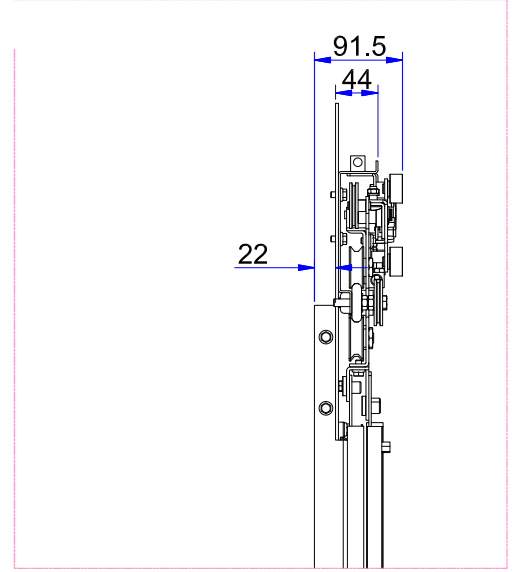
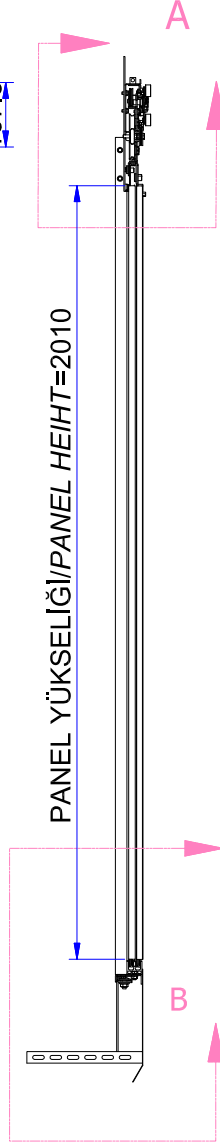
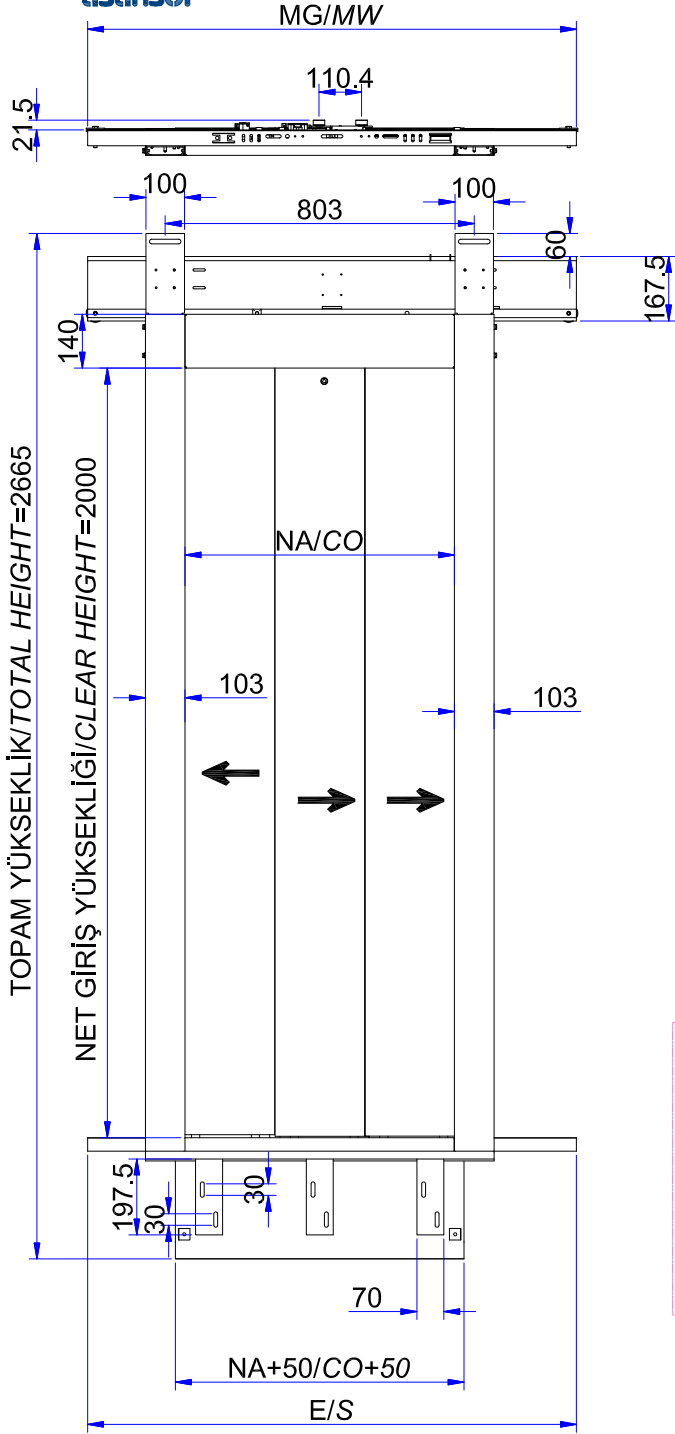

DETAY A /
DETAIL A

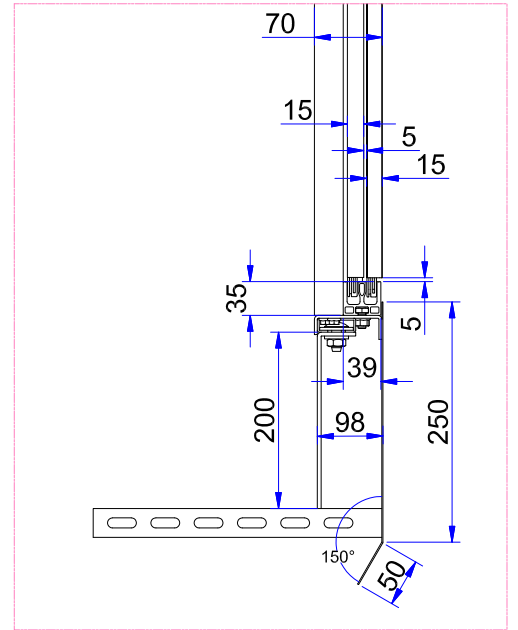

DETAY B /
DETAIL B

NA / CO : Net Giriş Açıklığı / Clear Opening
MG / MW : Mekanizma Geniřliđi / Mechanism Width
E / S : Eřik Uzunluđu / Sill Length
PG / PW : Panel Geniřliđi / Panel width

NET GİRİŞ AÇIKLIđINA GÖRE DEđİŐEN DEđERLER

NA/CO	700	750	800	850	900	950	1000	1050	1100	1150	1200
E/S(mm)	1270	1353,5	1437	1520,5	1604	1687,5	1771	1854,5	1938	2021,5	2105
MG/MW(mm)	1270	1353,5	1437	1520,5	1604	1687,5	1771	1854,5	1938	2021,5	2105
PG/PW(mm)	255,7	272,7	289,7	306,7	323,7	340,7	357,7	374,7	391,7	408,7	425,7

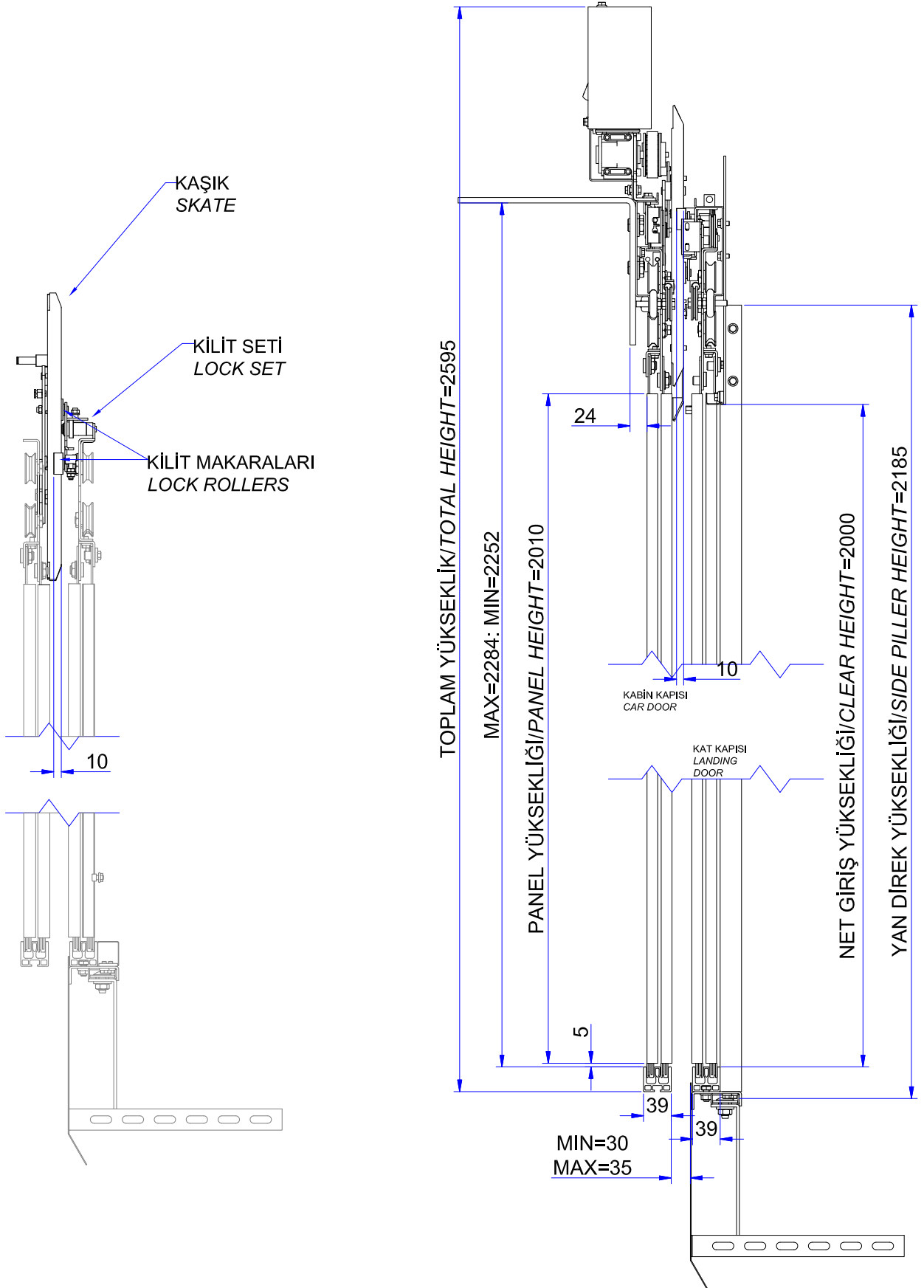

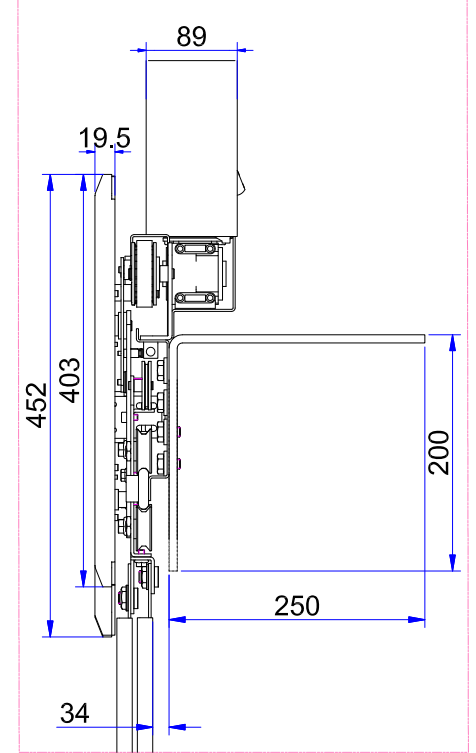
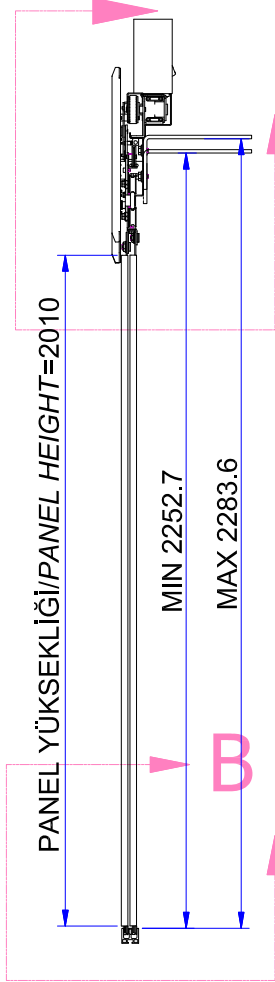
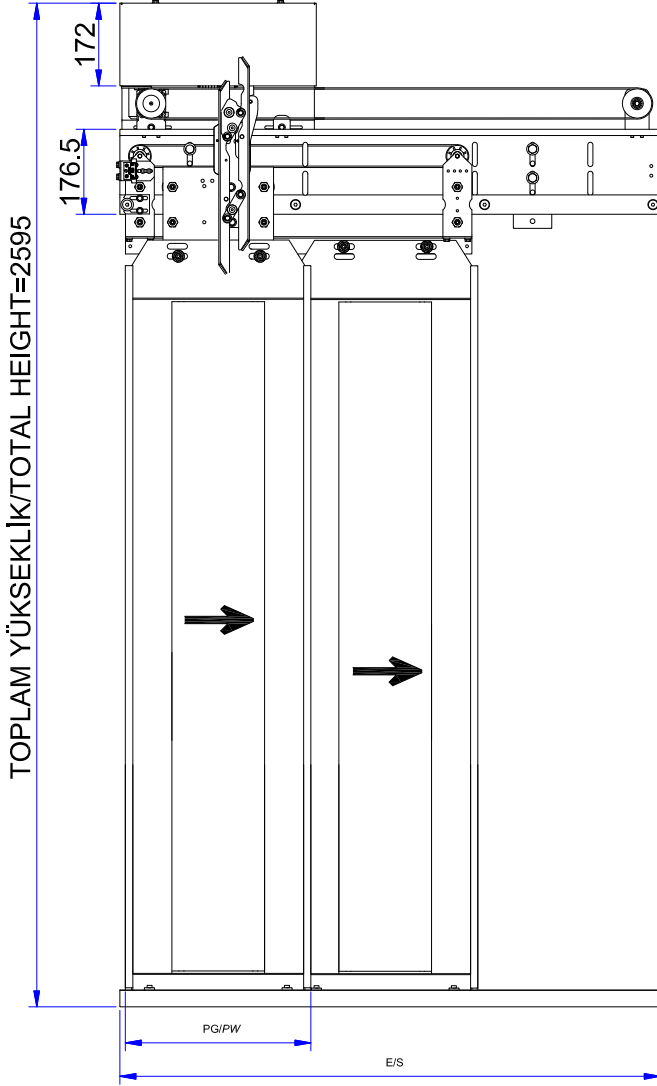
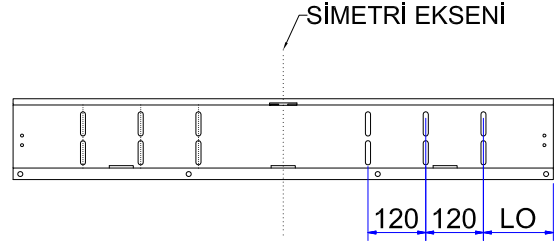
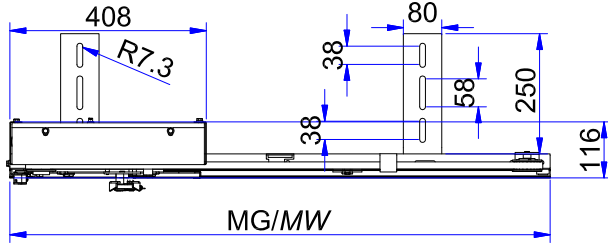

DETAIL A /
DETAIL A

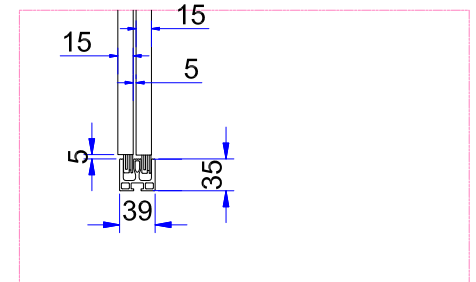

DETAIL B /
DETAIL B

NA / CO : Net Giriş Açıklığı / Clear Opening
MG / MW : Mekanizma Genişliği / Mechanism Width
E / S : Eşik Uzunluğu / Sill Length
PG/PW : Panel Genişliği / Panel width

NET GİRİŞ AÇIKLIĞINA GÖRE DEĞİŞEN DEĞERLER

NA/CO	700	750	800	850	900	950	1000	1050	1100	1150	1200
E/S(mm)	1123	1198	1273	1348	1423	1498	1573	1648	1723	1798	1873
MG/MW(mm)	1188	1263	1338	1413	1488	1563	1638	1713	1788	1863	1938
PG/PW(mm)	385	410	435	460	485	510	535	560	585	610	635

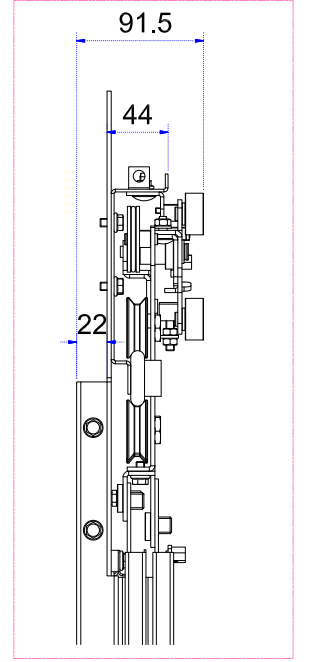
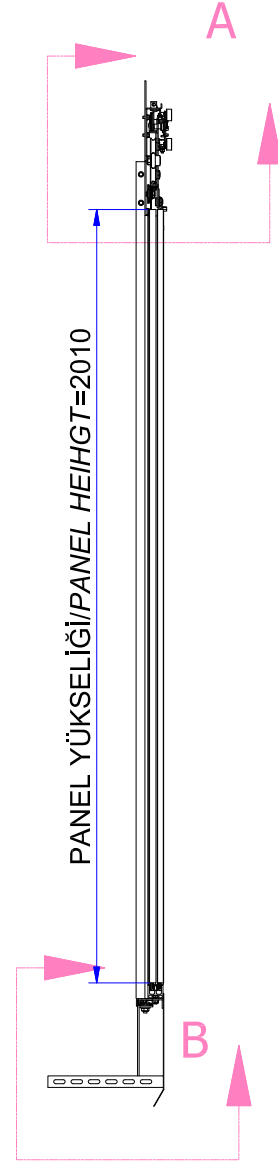
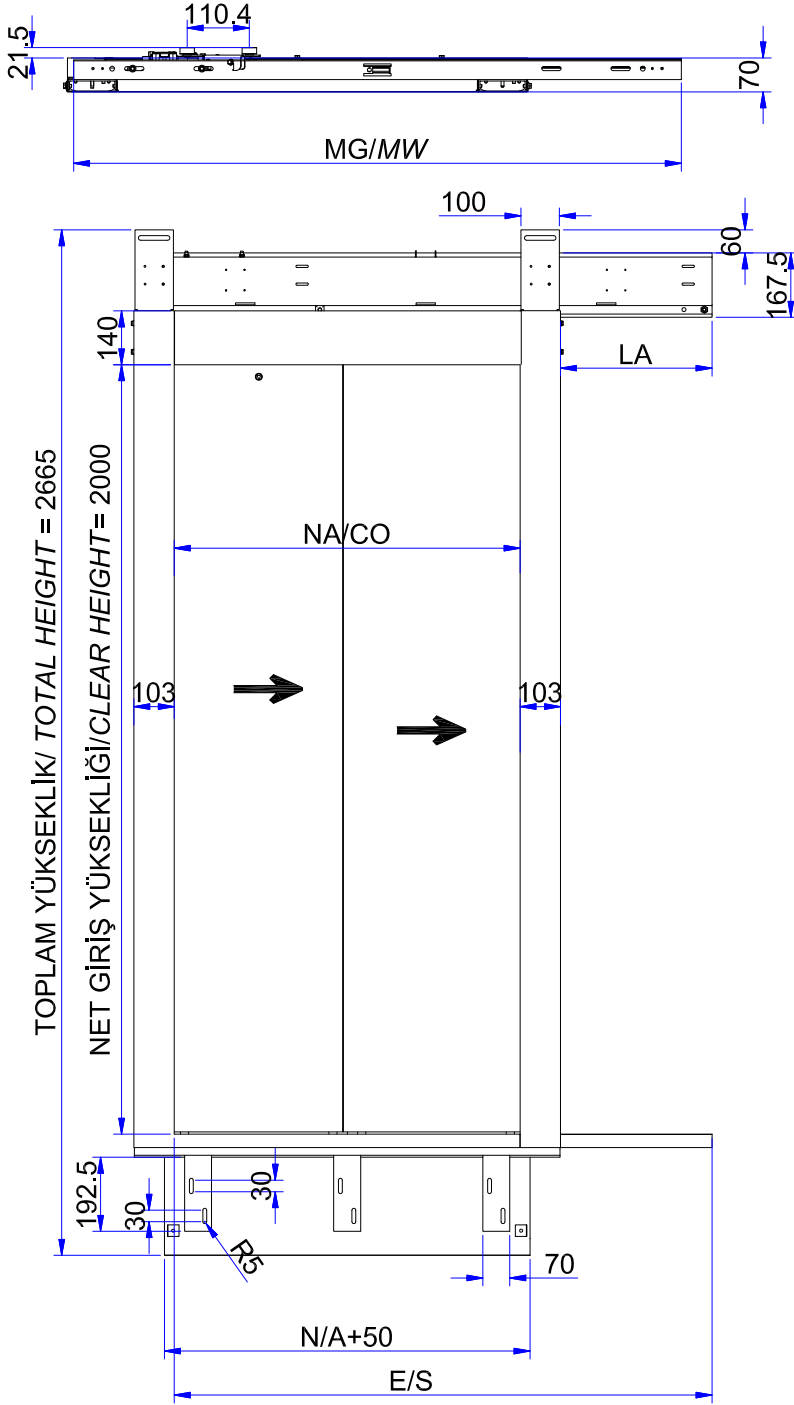

DETAIL A /
DETAIL A

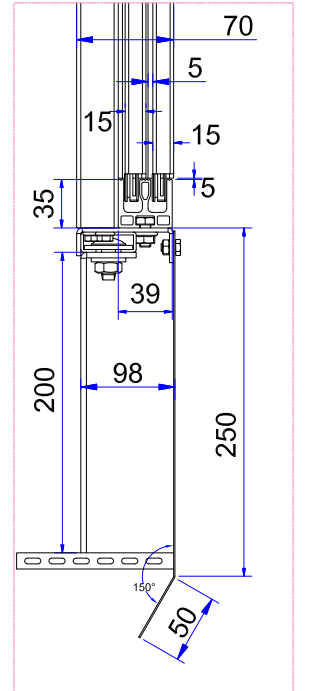

DETAIL B /
DETAIL B

NA / CO : Net Giriş Açıklığı / Clear Opening
MG / MW : Mekanizma Genişliği / Mechanism Width
E / S : Eşik Uzunluğu / Sill Length
PG/PW : Panel Genişliği / Panel width

NET GİRİŞ AÇIKLIĞINA GÖRE DEĞİŞEN DEĞERLER

NA/CO	700	750	800	850	900	950	1000	1050	1100	1150	1200
E/S(mm)	1123	1198	1273	1348	1423	1498	1573	1648	1723	1798	1873
LA(mm)	293,7	318,7	343,7	368,7	393,7	418,7	443,7	468,7	493,7	518,7	543,7
MG/MW(mm)	1188	1263	1338	1413	1488	1563	1638	1713	1788	1863	1938
PG/PW(mm)	385	410	435	460	485	510	535	560	585	610	635

